



Supplementary Regulation 2 & 4 WHEELERS OPEN

27th 28th & 29th March 2020@

**Taneja Aerospace and Aviation Limited,
Belagondapalli, Village, Thally Road, Denkanikotta Taluk,
Belagondapalli – 635 114, Tamil Nadu - India.**

Organised By:



APPROVED BY



The Federation of Motor Sports Clubs of India

**(National Sports Federation recognized by the FIA, FIM &
Government of India)**

Name of the event	VROOM 6 TH EDITION
Start Date of the event	27/03/2020
End Date of the event	29/03/2020
Status of the event	OPEN
Category	2 4 W
Name of the Organizer	SPEEDWAY MOTORSPORTS
Address	SHOP NO 3 , KRUPS ARUSHI APTS , WEST MAREEDAPALLY MAIN ROAD , SEC-BAD. PHONE : 988511144
Phone	9246526520
Email	mandeep_dhingra@hotmail.com
Website	www.speedwaymotorsports.in
In Association with (if any)	
Name of the Organizer	VROOM
Address	Smart Avenue, 3rd Floor, Coles Road, Opp. to Reliance Fresh, above Mambos Cafe, Pulkeshi Nagar, Frazer Town, Bengaluru, Karnataka 560005 .
Phone	7022450500
Email	tariq.m@genevaservices.in
Website	www.vroomgeneva.com

Supplementary Regulations

Approved by



WARNING

MOTORSPORT CAN BE DANGEROUS. DESPITE ORGANIZERS TAKING ALL POSSIBLE PRECAUTIONS UNAVOIDABLE ACCIDENTS MAY HAPPEN. YOU ARE PRESENT HERE AT YOUR OWN RISK.

TABLE OF CONTENTS

1. INTRODUCTION	4
2. ORGANIZATION	4
3. PROGRAMME	6
4. ENTRIES	7
5. INSURANCE	9
6. ADVERTISEMENT AND IDENTIFICATION	9
7. ADMINISTRATIVE CHECKS	10
8. PRE-EVENT SCRUTINEERING, SEALING AND MARKING	10
9. IDENTIFICATION OF OFFICIALS	10
11. PRIZES	11
12. PROTEST & APPEAL	11
13. RUNNING OF THE EVENT	12
14. SAFETY REQUIREMENTS	13
NAMES AND PHOTOGRAPHS OF CRO'S	14

Introduction

The event is run in compliance with the 2019 International Sporting Code of the Federation Internationale de l'Automobile (FIA), 2019 FMSCI General Prescriptions for Drag Racing, the 2019 2 & 4 wheeler the relevant Drag Technical Regulations and these Supplementary Regulations (SRs).

The Federation of Motor Sports Clubs of India (FMSCI) is the National Sporting Authority (ASN) of FIA in India.

Modifications, amendments and / or changes to these SRs will be announced only by numbered and dated bulletins, issued by the organizers, approved by the FMSCI or Stewards.

1.1 Acquaintance with and submission to Rules

Every person or group of persons, organizing a competition or taking part therein

- Shall be deemed to be acquainted with all the relevant rules and regulations of the FMSCI
- All competitors must sign the indemnity and declaration form, which are enclosed with the Entry Form
- These are conditions precedent attached to the submission of entries and taking part in an event and all competitors participating shall be bound by them and also the rules and regulations hereinafter set out or amendments made thereto.
- Shall undertake to submit themselves without reserve to the above and to the decision and consequences resulting therefrom.

Organization

2.1 FMSCI Permit No./s :

2.2 Organizers name, address and contact details

SPEEDWAY MOTORSPORTS
SHOP NO 3 , KRUPS ARUSHI APTS , WEST MAREEDAPALLY MAIN ROAD ,
SEC-BAD. PHONE : 988511144 9246526520
mandeep_dhingra@hotmail.com
www.speedwaymotorsports.in

2.3 Managing Committee

S MANDEEP SINGH DHINGRA	TARIQ MOHSIN	NARESH C RAMAN

2.4 Organizing Committee

S MANDEEP SINGH DHINGRA	TARIQ MOHSIN	NARESH C RAMAN
KHALID MOHSIN	ABRARULLA SHARIFF	

2.5 FMSCI Officials

Chief Steward	SAMEER PATEL
Steward	SRIKANTH ARAZA
Steward	Dr I VENKAT RAO
Chief Scrutineer	MR.SUBHASH CHANDRA BOSE MR. SAJEEV MATHEW RAJAN

2.6 Senior Officials

Clerk of the Course	S MANDEEP SINGH DHINGRA
Assistant Clerk of the Course	TARIQ MOHSIN
Secretary of the Meet	NARESH C RAMAN
Chief Safety Officer	ABDUL MATEEN
Chief Medical Officer	DOCTOR FROM AMBULANCE
Chief Time Keeper	NARESH C RAMAN
Competitors Relations Officer	TARIQ MOHSIN
Media Relations Officer	MOHAMMED ANAS JAVEED
Results Co-ordinator	KAMESH
Asst Scrutineer 2w	DAVIND THOMAS
Asst Scrutineer 4W	S PADMANABAN

2.7 Location of HQ

From :

Day	DD / MM / YYYY	Time (hrs)	Venue
	01/03/2020	09:00	Smart Avenue, 3rd Floor, Coles Road, Opp. to Reliance Fresh, above Mambos Cafe, Pulkeshi Nagar, Frazer Town, Bengaluru, Karnataka 560005 . Phone 7022450500

To :

WEDNESDAY	25/03/2020	18:00	Smart Avenue, 3rd Floor, Coles Road, Opp. to Reliance Fresh, above Mambos Cafe, Pulkeshi Nagar, Frazer Town, Bengaluru, Karnataka 560005 . Phone 7022450500
-----------	------------	-------	---

From :

Day	DD / MM / YYYY	Time (hrs)	Venue
THURSDAY	26/03/2020	09:00	Taneja Aerospace; Housur

To :

SUNDAY	28/03/2020	18:00	Taneja Aerospace ; Housur
--------	------------	-------	---------------------------

Programme

	Description	Venue	Time and Date
A	Entries open with publication of these Regulations	N.A	Publication of SR's
B	Closing of Entries	Vroom	15/03/2020 @ 16:00 Hrs.
C	Closing of Late Entries	Same As Above	22/03/2020 @ 14:00 Hrs.
D	Last date for withdrawal of Entries	Same As Above	22/03/2020 @ 18:00 Hrs.
E	Document Verification	Same As Above	23/03/2020 @ 09:00 hrs.
F	Pre-event scrutiny of vehicle 2W	Taneja Aerospace	27/03/2020 @ 9:00 Hrs. Schedule : Check Notice Board
G	Pre-event scrutiny of vehicle 4W	Taneja Aerospace	27/03/2020@ 9:00 Hrs. Schedule : Check Notice Board
H	Compulsory Practice 2W	Taneja Aerospace	28/03/2020 @ Check Notice Board
I	Compulsory Practice 4W	Taneja Aerospace	29/03/2020 @ Check Notice Board
J	2 wheelers Compulsory Rider's Briefing	Taneja Aerospace	28/03/2020 Schedule : TBA
K	4 wheeler's Compulsory Driver / Rider Briefing	Taneja Aerospace	29/03/2020 Schedule : TBA
L	Start of Drag 2w	Taneja Aerospace	28/03/2020 SCHEDULE 2W Classes M1 TO M7
M	Start of Drag 2w / 4w	Taneja Aerospace	29/03/2020 SCHEDULE 2W/4W M8 TO M13 B1 TO B6 D1 TO D8 F1 TO F3
N	Prize Distribution	Taneja Aerospace	28 th & 29 th March 2020

Entries

4.1 Opening and Closing Dates

Entries open with the publication of these Supplementary Regulations
Closing date of all entries: Check Program

4.2 Entry Procedure

Those wishing to take part in the event must send the enclosed entry form duly completed to the permanent secretariat address given in Art.2.2 prior to the closing date as mentioned in Art.4.1

4.4 Maximum number of Entries

The maximum number of entries accepted would be no more than 400. If more entries are than these are received, then the organizers reserve the right to decide which entries would be accepted.

4.5 Minimum number of entries for each class is 6. However, if insufficient entries have been received for a class; the organizers reserve the right to cancel or abandon a class or merge a class with a higher class in liaison with the Stewards of the event, if they feel appropriate.

4.6 Maximum of 2 drivers / riders are allowed for each bike in any category. A participant can take part in as many classes as he/she wants, however this should be on different bikes.

4.4 Category, Groups & Classes & Entry Fees

2 Wheelers : 2 Stroke : Super Sport	
Class	Entry Fees
M1 Upto 130 cc	3000
M2 131 cc – 165 cc	3000
M3 350 cc and above	3000

2 Wheelers : 4 Stroke : Super Sport	
Class	Entry Fees
M4 Upto 165 cc	3000
M5 166 cc – 225 cc	3000
M6 226 cc – 360 cc	3000
M7 361 cc – 550 cc	3000
M8 551 cc – 850 cc	5000
M9 851 cc – 1050 cc	5000
M10 1051 cc and above	5000

M11 Single / Twin 551 cc – 850 cc	5000
M13 Unrestricted Class	6000

4 Wheelers : Pro Stock Petrol	
Class	Entry Fees
B1 Upto 1150 cc	5000
B2 1151 cc – 1450 cc	5000
B3 1451 cc – 1650 cc	5000
B4 1651 cc – 2050 cc	5000
B5 2051 cc – 2550 cc	5000
B6 2551 cc – 3060 cc	5000
B6 3061 cc and above	5000

4 Wheelers : Pro Stock Diesel	
Class	Entry Fees
D1 Upto 1150 cc	5000
D3 1151 cc – 1450 cc	5000
D4 1451 cc – 1650 cc	5000
D5 1651 cc – 2050 cc	5000
D6 2051 cc – 2550 cc	5000
D7 2551 cc – 3060 cc	5000
D8 3061 cc and above	5000

F1 - 4 Wheelers : Indian Open Stock Body - 7000

F2 - 4 Wheelers : Indian Open Altered Body – 7000

F3 - 4 Wheelers : Unrestricted Class – 7000

*GST 18% applicable.

4.5 Payment

The entry fees can be either by demand draft in favour of VROOM payable at BANGALORE or by cash or by wire transfer. Forms can be courier to the following address VROOM ; Smart Avenue, 3rd Floor, Coles Road, Opp. to Reliance Fresh, Above Mambos Cafe, Pulkeshi Nagar, Frazer Town, Bengaluru, Karnataka 560005 . Phone 7022450500

Name of Bank	ICICI BANK
Branch	COX TOWN
Nature of Account	Current
Account No.	025205004825
IFSC Code	ICIC0000252

4.6 Refund

Entries fees will be refunded in full only

- To candidates whose entry has not been accepted
- In case of event not taking place

The organizers may refund 50% of the entry fee to those competitors who, for reasons of force-majeure (duly accepted by the organizing committee) were unable to start in the event.

Insurance

Organizers holding a valid 2019 FMSCI Permit for an event are covered for

Competitors : A maximum of 250 competitors with valid FMSCI Competition License participating in various events across the Country on a given day are covered for Personal Accident Insurance for Rs. 5 lakhs with Rs. 5 Lakhs medical expense extension per person.

Officials: A maximum of 100 officials officiating in various events across the Country on a given day are covered for Personal Accident Insurance for Rs.25 lakhs with Rs.1 lakh medical expense extension per person.

THESE INSURANCES ARE ISSUED BY NEW INDIA INSURANCE COMPANY LTD AND VALID DURING THE RUNNING OF THE EVENT ONLY. ORGANIZERS / COMPETITORS ARE ADVISED TO TAKE ANY ADDITIONAL INSURANCES THEY MAY DEEM FIT. IF THEY HAVE MORE THAN 100 OFFICIALS & ALSO REQUIRE DOOR TO DOOR COVERAGE PLEASE CONTACT: S.MANIKANDAN@STENHOUSE.IN

Third Party Liability Insurance (Minimum 50 lakhs) taken by the Organizers

Details of the insurance cover will be available one week prior to the event dates.

Dates covered: TBA

Amount: TBA

Company: TBA

Advertisement and Identification

- 6.1 It is compulsory to carry organizers advertisement on the competing vehicles.
- 6.2 Competitors are allowed to affix any kind of advertisements on their vehicle provided that
 - Any instructions issued by the organisers are observed.
 - It is authorized by the National laws and FMSCI regulations

- Advertising must not be of a political, obscene or insulting nature. It must be in good taste and not conflict with the vehicles official numbers in any way
- It should not be placed as to prevent recognition by Officials or Marshals.
- The space designated in Appendix '4' of the General Prescription is left free of advertising other than that provided by the organisers.
- f It does not encroach upon the spaces reserved for rally plates, number plates and windscreen strips,
- It does not interfere with the driver's vision through the windows.

Administrative checks

7.1 Documents Submission

Entrants should produce the following for inspection at the time of submitting the vehicle for pre-event scrutiny and administrative check on the date / time as mentioned in Art.3.

Competitors are required to bring:

- i) Special Drag Insurance cover valid for the dates of the event (Recommended)
- ii) Authority letter from owner of the vehicle if the driver / rider is not the owner of the vehicle used in the event
- iii) FMSCI Competition License for Driver/Rider (Minimum 4W / 2W
- iv) Apply for competition licence online on <http://licence.fmsci.co.in/>)
- v) Entrant Licence / FMSCI Registration (if any)
- vi) Pan Card copy of Competitor
- vii) 2 Passport size photographs

Competitors are required to carry all the above documents throughout the event. All the documents shall be valid for the date of the event.

Pre-event Scrutineering, Sealing and Marking

8.1 Venue & Timings

Place : **Taneja Aerospace and Aviation Limited, Belagondapalli, Village, Thally Road, Denkanikotta Taluk, Belagondapalli – 635 114, Tamil Nadu - India.**

Date: 27th March 2020

Time: 08:00 to 18:00 Hrs.

Identification of Officials

Safety Marshal	Orange
Safety Officer	Orange with white stripe and text
Post Chief	Blue with white stripe and text

Media	Green
Stage Commander	Red with text
Competitor Relations Officer	Red Jacket or Red Tabard
Medical	White
Radio	Yellow with blue mark
Scrutineer	Black

Prizes

1st Place – Trophy

2nd Place – Trophy

3rd Place – Trophy

Protest & Appeal

12.1 LODGING A PROTEST OR APPEAL

All protests and / or appeals must be lodged in accordance with the stipulations of Articles 13, 14 and 15 of the Code.

12.2 PROTEST FEES

12.2.1 For Closed, Closed Invitation and Open Events, the protest fees is ₹7,080/= (Rupees Seven Thousand Eighty Only) (₹6,000/= + ₹1080 GST)

12.2.2 If a protest requires the dismantling and re-assembly of a clearly defined part of the car any additional deposit must be specified in the Supplementary Regulations– or will be specified by the Stewards upon a proposal of the FMSCI Technical Delegate / Chief Scrutineer.

12.2.3 If the protest is overruled or it is withdrawn after being brought, no part of the fee shall be returned. (Article 13.10.1 of FIA International Sporting Code)

12.2.4 If it is proved that the author of the protest has acted in bad faith, the FMSCI may inflict upon them one of the penalties laid down in the Code. (Article 13.10.3 of sporting code)

12.3 APPEALS

₹113,280/= (Rupees One Lakh Thirteen Thousand Two Hundred Eighty Only) (₹96,000/= + ₹17,280/= GST)

- Competitors may appeal against decisions, in accordance with the stipulations set out in Articles 15.1 of the Code.
- Competitors have the right to appeal against a sentence or other decisions pronounced on them by the Stewards of the meeting. They must, however under pain of forfeiture of their right to appeal, notify the Stewards of the Meeting in writing within one hour of the publication of the decision, of their intention to appeal along with a fee of ₹56,640/= (Rupees Fifty Six Thousand Six Hundred Forty only).
- The right to bring an appeal to the FMSCI expires 96 hours after the date of the decision of the Stewards of the event on condition that the intention

of appealing has been notified in writing to the Stewards of the event within one hour of the decision (see previous paragraph). This appeal may be brought by fax or by any other electronic means of communication with confirmation of receipt. Confirmation by a letter of the same date accompanied by the necessary fee is required. The FMSCI will give its decision within a maximum of 30 days.

- All parties concerned shall be given adequate notice of the hearing of any appeal. They shall be entitled to call witnesses, but their failure to attend the hearing shall not interrupt the course of the proceedings.
- The confirmation of an appeal to the FMSCI must be accompanied by the grounds of appeal along with fee of ₹113,280/= (Rupees One Lakh Thirteen Thousand Two Hundred Eighty Only).
- This fee becomes due from the moment the appellant notifies the Steward of the intention of appealing, and remains payable even if the appellant does not follow up the declared intention to appeal.
- If the appeal is rejected or it is withdrawn after being brought, no part of the fee shall be returned.
- If judged partially founded, the fee may be returned in part, and in its entirety if the appeal is upheld.
- If it is proved that the author of the appeal has acted in bad faith, the FMSCI may inflict upon them one of the penalties laid down in the Code.

Running of the Event

Distance : 402 metres 1/4 mile

Width of the track : 150 Feet X 7000 Feet

Maximum Number of runs per day including practice : As per G.P

13.1 Format of Racing

STARTING LINE & STAGING PROCEDURES

The class that is to run will be announced, followed by the competition numbers of each bike participating in that class. Competition numbers will be announced in pairs in the order of racing precedence.

The first pair of bikes will be called to the starting line by their competition numbers. When the first bike arrives at the starting line, the second bike has **one (1) minute** to arrive and stage at the starting line.

– Bikes that fail to stage at the starting line within one minute may be immediately disqualified.

There will be no choice of lane.

13.2 Starting lights will be used. The Starting Lights will be 3 Amber light followed by a Green light for GO,

13.3 The bikes will be judged according to timings. Timing will be recorded by a laser trigger. The timing will be recorded from the time the lights go GREEN up to when the rider crosses the finish line.

13.4 If a rider makes a false / jump-start, the RED light will come on and the participant will be EXCLUDED from that particular run. If the lights fail, there shall be a manual timing system for that entire class. For the classes that have already been completed, the timing light time shall remain. There shall be no Protest entertained on Jump Starts and Timings when the Timing Equipment is used.

13.5 Only Riders along with their competing vehicles shall be allowed in the starting area and for Line-Up. No other person shall be allowed into the starting area.

13.6 Once the vehicle has finished its run, the competitors have to go to the end of the Track and return via the road for which the speed limit will be 30Kms/hr. The competitors may have to wait to be escorted back by the organizers.

13.7 The procedures and other details of the drag shall be informed to all competitors at the Briefing Meeting.

13.8 The CLASS & CATEGORY Winners will be determined by the fastest timings. All class/category-winning vehicles will be then taken to Parc Ferme for post event scrutiny.

13.9 The bikes used for qualifying cannot be changed on the race day. If done will entail disqualification.

Safety Requirements

AS per G.P

Names and photographs of CRO's

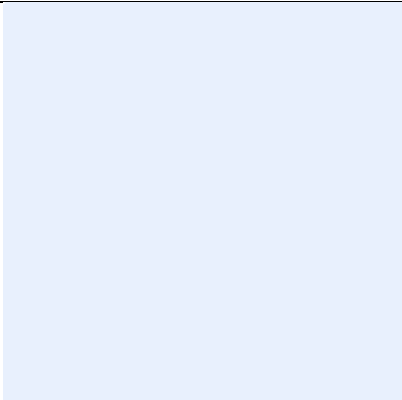
	
TARIQ MOHSIN	CRO NAME
7022450500	MOBILE
tariq.m@genevaservices.in	email

Will be present at:

- At the Secretariat.
- At the start of the scrutineering.
- Near the "PIT AREA".

NOTES / WAIVERS

The rider or his official representative must present any bike taking part in the event to Scrutinising. Competitors reporting later than their schedule will be penalized by Rs.100/- per minute later than their slot up to maximum of 30 minutes lateness allowed, after which they may be disqualified.

1 Each bike must carry the competition number and the advertising stickers provided by the Organizers. The details of where to put the advertising stickers and the competition number will be given at the briefing meeting. The competitors are allowed to carry any other kind of advertisements on their bike provided that: (a) it is authorized by the National laws and FMSCI regulations (b) it is not likely to cause any offence (c) it is not political or religious in nature (d) it does not encroach upon the space reserved for plates, competition number and organizers stickers (e) it does not interfere with rider vision.

2 Top three 2-Wheelers in each category will be subject to compulsory post event scrutiny. Other finishers will be held in parc ferme and can only leave on the approval of the organiser. The participants must come prepared with their own mechanics at the time of Scrutiny.

3 The Scrutineers of the event at their discretion can dismantle any competitor's 2-wheeler for inception at any given time during the course of the event.

4 PIT CREW - Each rider shall be given 1 pit pass per bike entered. Photographs for the pit crew should be presented at the time of documentation.

5. ADVERTISING

The competitors are allowed to carry any other kind of advertisements on their bike provided that

It is authorized by the National laws and FMSCI regulations

It is not likely to cause any offence

It is not political or religious in nature

It does not encroach upon the space reserved for plates, competition number and organizers stickers

It does not interfere with rider's vision.

The competition numbers and compulsory stickers shall be affixed on the vehicles before scrutineering and shall remain affixed throughout the event.

6. APPAREL - Each member of a participant crew must be fully attired when present in the staging, starting and competition areas of the race track. Shoes are mandatory. Shorts, bare legs, tank tops, or bare torsos are prohibited when driving in any class. See Class Requirements

7. APPEARANCE - Vehicles participating in drag racing events must be presentable in appearance at all times; those considered improperly prepared may be rejected by the scrutineer. The appearance of personnel attending contestant vehicles is equally important, and is subject to the same considerations.

8 PENALTIES

8.1 False Start / Jump Start: A false start occurs when the vehicle moves forward or backwards from the prescribed position before the Green lights. The penalty for this is **DISQUALIFICATION**. However a competitor can only take one jump start re run per class as per the following table.

Category	Amount
Indian 2 Wheelers	1500
Foreign 2 Wheelers	2000
Indian 4 Wheelers	4000
Foreign 4 Wheelers	5000

The Start Marshal's decision will be Final.

8.2 Refusal to obey officials of the meet- left to the discretion of the Steward.

8.3 Riding dangerously in restricted area - left to the discretion of the Steward.

8.4 Crossing of centre line – **DISQUALIFICATION**

8.5 If a competitor arrives late for starting, he/she shall not be allowed to start.

8.6 Any rider found riding fast, rashly or negligently, or practicing or tuning their bikes on the track may be **DISQUALIFIED**

8.7 Any competitor who does not have his / her I.D. Tag shall not be allowed to start.

8.8 There will be a speed limit on the return run of 30 KMPH. Any competitor found breaking this speed limit **MAY BE DISQUALIFIED**

8.9 The Stewards of the meet may adjudicate on any matter not covered by these regulations and impose penalties in accordance with the Code.

8.10 Burnout are allowed for vehicles running 'DRAG SLICK TYRES' only in the prescribed area on the drag strip any infringement by the competitor will attract a cash penalty of Rs.1500 per run.

8.11 A racer found not conforming to these Supplementary regulations or by refusing to make their vehicle available for inspection may be disqualified from the event.

8.12 Disqualification if a bike found over bored beyond its cubic capacity allowed in its class.

8.13 The bikes used for qualifying cannot be changed on the race day. If done will entail disqualification.

8.14 Winner's vehicles from each class will be subject to a complete post event scrutiny for which the owner will bear costs.

8.15 Not present at driver's briefing report to Stewards and cash penalty up to Rs 2500.

Article 9 RESULTS

9.1 Results will be posted on the official notice board after each race.

9.2 Results will also be displayed on screens after each race

9.3 Reaction Time (RT) + Elapsed Time (ET) = Final Time (FT)

9.4 **Tie Breaker:** In case of a tie, the competitor with the least reaction time shall be declared the winner. Reaction time is the time taken by a competitor to take off after the Green GO Light comes on. If the Tie is still not resolved, the award/s will be divided amongst both the competitors.

9.5 If a vehicle is disqualified for technical or whatever reason, the vehicle placed behind him will move up to take the position.

APPENDIX 1: COMPETITION NUMBERS & ADVERTISING

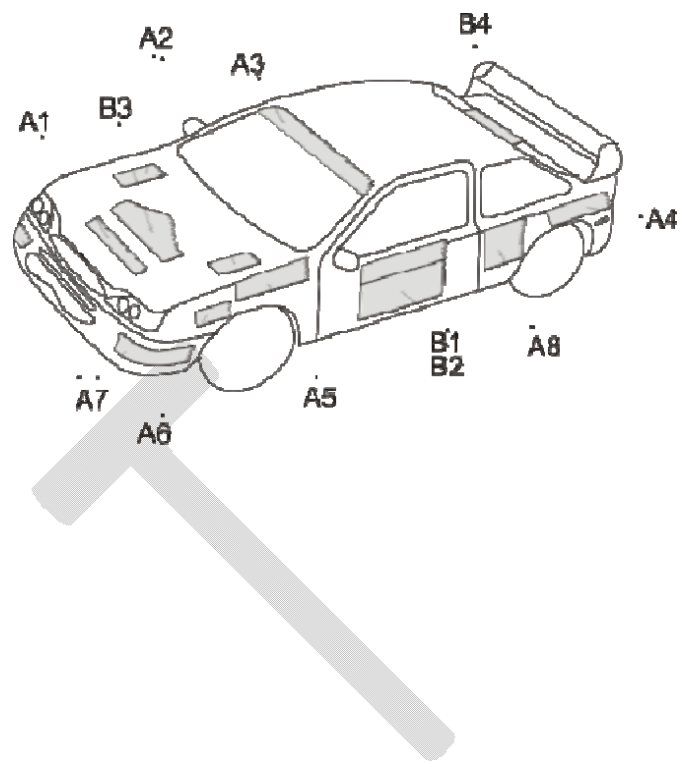

- A1 : TBA
- A2 : Club/Sponsor
- A3 : Sponsor
- A4 : Sponsor
- A5 : TBA
- A6 : TBA
- A7 : TBA
- B1 ~ B3: Competition Number



Supplementary Regulation 2 & 4 WHEELERS OPEN

27th 28th & 29th March 2020@

**Taneja Aerospace and Aviation Limited,
Belagondapalli, Village, Thally Road, Denkanikotta Taluk,
Belagondapalli – 635 114, Tamil Nadu - India.**

Organised By:



APPROVED BY



The Federation of Motor Sports Clubs of India

**(National Sports Federation recognized by the FIA, FIM &
Government of India)**

Name of the event	VROOM 6 TH EDITION
Start Date of the event	27/03/2020
End Date of the event	29/03/2020
Status of the event	OPEN
Category	2 4 W
Name of the Organizer	SPEEDWAY MOTORSPORTS
Address	SHOP NO 3 , KRUPS ARUSHI APTS , WEST MAREEDAPALLY MAIN ROAD , SEC-BAD. PHONE : 988511144
Phone	9246526520
Email	mandeep_dhingra@hotmail.com
Website	www.speedwaymotorsports.in
In Association with (if any)	
Name of the Organizer	VROOM
Address	Smart Avenue, 3rd Floor, Coles Road, Opp. to Reliance Fresh, above Mambos Cafe, Pulkeshi Nagar, Frazer Town, Bengaluru, Karnataka 560005 .
Phone	7022450500
Email	tariq.m@genevaservices.in
Website	www.vroomgeneva.com

Supplementary Regulations

Approved by



WARNING

MOTORSPORT CAN BE DANGEROUS. DESPITE ORGANIZERS TAKING ALL POSSIBLE PRECAUTIONS UNAVOIDABLE ACCIDENTS MAY HAPPEN. YOU ARE PRESENT HERE AT YOUR OWN RISK.

TABLE OF CONTENTS

1. INTRODUCTION	4
2. ORGANIZATION	4
3. PROGRAMME	6
4. ENTRIES	7
5. INSURANCE	9
6. ADVERTISEMENT AND IDENTIFICATION	9
7. ADMINISTRATIVE CHECKS	10
8. PRE-EVENT SCRUTINEERING, SEALING AND MARKING	10
9. IDENTIFICATION OF OFFICIALS	11
11. PRIZES	11
12. PROTEST & APPEAL	11
13. RUNNING OF THE EVENT	12
14. SAFETY REQUIREMENTS	13
NAMES AND PHOTOGRAPHS OF CRO'S	14

Introduction

The event is run in compliance with the 2019 International Sporting Code of the Federation Internationale de l' Automobile (FIA), 2019 FMSCI General Prescriptions for Drag Racing, the 2019 2 & 4 wheeler the relevant Drag Technical Regulations and these Supplementary Regulations (SRs).

The Federation of Motor Sports Clubs of India (FMSCI) is the National Sporting Authority (ASN) of FIA in India.

Modifications, amendments and / or changes to these SRs will be announced only by numbered and dated bulletins, issued by the organizers, approved by the FMSCI or Stewards.

1.1 Acquaintance with and submission to Rules

Every person or group of persons, organizing a competition or taking part therein

- Shall be deemed to be acquainted with all the relevant rules and regulations of the FMSCI
- All competitors must sign the indemnity and declaration form, which are enclosed with the Entry Form
- These are conditions precedent attached to the submission of entries and taking part in an event and all competitors participating shall be bound by them and also the rules and regulations hereinafter set out or amendments made thereto.
- Shall undertake to submit themselves without reserve to the above and to the decision and consequences resulting therefrom.

Organization

2.1 FMSCI Permit No./s :

2.2 Organizers name, address and contact details

SPEEDWAY MOTORSPORTS
SHOP NO 3 , KRUPS ARUSHI APTS , WEST MAREEDAPALLY MAIN ROAD ,
SEC-BAD. PHONE : 988511144 9246526520
mandeep_dhingra@hotmail.com
www.speedwaymotorsports.in

2.3 Managing Committee

S MANDEEP SINGH DHINGRA	TARIQ MOHSIN	NARESH C RAMAN

2.4 Organizing Committee

S MANDEEP SINGH DHINGRA	TARIQ MOHSIN	NARESH C RAMAN
KHALID MOHSIN	ABRARULLA SHARIFF	

2.5 FMSCI Officials

Chief Steward	SAMEER PATEL
Steward	SRIKANTH ARAZA
Steward	Dr I VENKAT RAO
Chief Scrutineer	MR.SUBHASH CHANDRA BOSE MR. SAJEEV MATHEW RAJAN

2.6 Senior Officials

Clerk of the Course	S MANDEEP SINGH DHINGRA
Assistant Clerk of the Course	TARIQ MOHSIN
Secretary of the Meet	NARESH C RAMAN
Chief Safety Officer	ABDUL MATEEN
Chief Medical Officer	DOCTOR FROM AMBULANCE
Chief Time Keeper	NARESH C RAMAN
Competitors Relations Officer	TARIQ MOHSIN
Media Relations Officer	MOHAMMED ANAS
Results coordinator	KAMESH
Asst Scrutineer 2w	DAVIND THOMAS
Asst Scrutineer 4W	S PADMANABAN

2.7 Location of HQ

From :

Day	DD / MM / YYYY	Time (hrs)	Venue
	01/03/2020	09:00	Smart Avenue, 3rd Floor, Coles Road, Opp. to Reliance Fresh, above Mambos Cafe, Pulkeshi Nagar, Frazer Town, Bengaluru, Karnataka 560005 . Phone 7022450500

To :

WEDNESDAY	25/03/2020	18:00	Smart Avenue, 3rd Floor, Coles Road, Opp. to Reliance Fresh, above Mambos Cafe, Pulkeshi Nagar, Frazer Town, Bengaluru, Karnataka 560005 . Phone 7022450500
-----------	------------	-------	---

From :

Day	DD / MM / YYYY	Time (hrs)	Venue
THURSDAY	26/03/2020	09:00	Taneja Aerospace; Housur

To :

SUNDAY	28/03/2020	18:00	Taneja Aerospace ; Housur

Programme

	Description	Venue	Time and Date
A	Entries open with publication of these Regulations	N.A	Publication of SR's
B	Closing of Entries	Vroom	15/03/2020 @ 16:00 Hrs.
C	Closing of Late Entries	Same As Above	22/03/2020 @ 14:00 Hrs.
D	Last date for withdrawal of Entries	Same As Above	22/03/2020 @ 18:00 Hrs.
E	Document Verification	Same As Above	23/03/2020 @ 09:00 hrs.
F	Pre-event scrutiny of vehicle 2W	Taneja Aerospace	27/03/2020 @ 9:00 Hrs. Schedule : Check Notice Board
G	Pre-event scrutiny of vehicle 4W	Taneja Aerospace	27/03/2020@ 9:00 Hrs. Schedule : Check Notice Board
H	Compulsory Practice 2W	Taneja Aerospace	28/03/2020 @ Check Notice Board
I	Compulsory Practice 4W	Taneja Aerospace	29/03/2020 @ Check Notice Board
J	2 wheelers Compulsory Rider's Briefing	Taneja Aerospace	28/03/2020 Schedule : TBA
K	4 wheeler's Compulsory Driver / Rider Briefing	Taneja Aerospace	29/03/2020 Schedule : TBA
L	Start of Drag 2w	Taneja Aerospace	28/03/2020 SCHEDULE 2W Classes M14 TO M19
M	Start of Drag 2w / 4w	Taneja Aerospace	29/03/2020 SCHEDULE 2W/4W W & M12 S1 TO S7 FC, G, H,EX,WW
N	Prize Distribution	Taneja Aerospace	28 th & 29 th March 2020

Entries

4.1 Opening and Closing Dates

Entries open with the publication of these Supplementary Regulations
Closing date of all entries: Check Program

4.2 Entry Procedure

Those wishing to take part in the event must send the enclosed entry form duly completed to the permanent secretariat address given in Art.2.2 prior to the closing date as mentioned in Art.4.1

4.4 Maximum number of Entries

The maximum number of entries accepted would be no more than 400. If more entries are than these are received, then the organizers reserve the right to decide which entries would be accepted.

4.5 Minimum number of entries for each class is 6. However, if insufficient entries have been received for a class; the organizers reserve the right to cancel or abandon a class or merge a class with a higher class in liaison with the Stewards of the event, if they feel appropriate.

4.6 Maximum of 2 drivers / riders are allowed for each bike in any category. A participant can take part in as many classes as he/she wants, however this should be on different bikes.

4.4 **Category, Groups & Classes & Entry Fees** (GST 18% applicable).

2 Wheelers:

- M14 4 Stroke Open
- M15 Bullet Class Open
- M16 KTM Up to 250cc
- M17 KTM Above 251cc up to 390cc
- M18 Jawa / Yezdi Open
- M19 Ladies Class up to 390 cc 4 stroke
- W Foreign Bike Wheelie Class
- M12 Super Sport Indian Class

4 wheelers :

No car with a foreign Engine will be allowed to take part in the Indian Cars Category.

A vehicle may enter **only one** of the following categories. Only 2 drivers per car are allowed.

S – Street Stock Petrol

- S1 up to 1150 cc
- S2 1151 – 1450 cc
- S3 1451 to 1650 cc
- S4 1651 – 2050 cc
- S5 2051 – 2550 cc
- S6 2551 – 3060 cc
- S7 3061 cc and above

Only OE Turbo charging / super charging allowed, with a multiplication factor of 1.7 on the cubic capacity.

CLASSIFICATION FOR FOREIGN CARS

A vehicle may enter only one of the following categories and the unrestricted category. *No car with an Indian Engine will be allowed to take part in the Foreign Cars Category.*

FC Foreign Cars: (Pro - Stock) Turbo M factor cc X 1.7

- FC1 up to 3000 cc
- FC2 Above 3001 up to 4000 cc
- FC3 4001 cc and above

G. Indian Hatchback Open (NO NOS / TURBO)

H - Indian CARS: (Forced Induction / Nitrous Classes)

(A vehicle may enter only one of the following categories and the Indian Open category. Only 2 drivers per car are allowed.

Either nitrous OR supercharging / turbo charging of cars allowed, not both).

- H1 Indian Cars from 1101 to 1400 cc
- H2 Indian Cars from 1401 to 1650 cc
- H3 Indian Cars from 1651 to 2000 cc
- H4 Indian Cars from 2001 & Above

EX – Exhibition Class

WW - FIA Women in motorsports class – 4W

*GST 18% applicable.

4.5 Payment

The entry fees can be either by demand draft in favour of VROOM payable at BANGALORE or by cash or by wire transfer. Forms can be courier to the following address VROOM ; Smart Avenue, 3rd Floor, Coles Road, Opp. to Reliance Fresh, Above Mambos Cafe, Pulkeshi Nagar, Frazer Town, Bengaluru, Karnataka 560005 . Phone 7022450500

Name of Bank	ICICI BANK
Branch	COX TOWN
Nature of Account	Current
Account No.	025205004825
IFSC Code	ICIC0000252

4.6 Refund

Entries fees will be refunded in full only

- To candidates whose entry has not been accepted
- In case of event not taking place

The organizers may refund 50% of the entry fee to those competitors who, for reasons of force-majeure (duly accepted by the organizing committee) were unable to start in the event.

Insurance

Organizers holding a valid 2019 FMSCI Permit for an event are covered for

Competitors : A maximum of 250 competitors with valid FMSCI Competition License participating in various events across the Country on a given day are covered for Personal Accident Insurance for Rs. 5 lakhs with Rs. 5 Lakhs medical expense extension per person.

Officials: A maximum of 100 officials officiating in various events across the Country on a given day are covered for Personal Accident Insurance for Rs.25 lakhs with Rs.1 lakh medical expense extension per person.

THESE INSURANCES ARE ISSUED BY NEW INDIA INSURANCE COMPANY LTD AND VALID DURING THE RUNNING OF THE EVENT ONLY. ORGANIZERS / COMPETITORS ARE ADVISED TO TAKE ANY ADDITIONAL INSURANCES THEY MAY DEEM FIT. IF THEY HAVE MORE THAN 100 OFFICIALS & ALSO REQUIRE DOOR TO DOOR COVERAGE PLEASE CONTACT: S.MANIKANDAN@STENHOUSE.IN

Third Party Liability Insurance (Minimum 50 lakhs) taken by the Organizers

Details of the insurance cover will be available one week prior to the event dates.

Dates covered: TBA

Amount: TBA

Company: TBA

Advertisement and Identification

6.1 It is compulsory to carry organizers advertisement on the competing vehicles.

- 6.2 Competitors are allowed to affix any kind of advertisements on their vehicle provided that
- Any instructions issued by the organisers are observed.
 - It is authorized by the National laws and FMSCI regulations
 - Advertising must not be of a political, obscene or insulting nature. It must be in good taste and not conflict with the vehicles official numbers in any way
 - It should not be placed as to prevent recognition by Officials or Marshals.
 - The space designated in Appendix '4' of the General Prescription is left free of advertising other than that provided by the organisers.
 - f It does not encroach upon the spaces reserved for rally plates, number plates and windscreen strips,
 - It does not interfere with the driver's vision through the windows.

Administrative checks

7.1 Documents Submission

Entrants should produce the following for inspection at the time of submitting the vehicle for pre-event scrutiny and administrative check on the date / time as mentioned in Art.3.

Competitors are required to bring:

- i) Special Drag Insurance cover valid for the dates of the event (Recommended)
- ii) Authority letter from owner of the vehicle if the driver / rider is not the owner of the vehicle used in the event
- iii) FMSCI Competition License for Driver/Rider (Minimum 4W / 2W)
- iv) Apply for competition licence online on <http://licence.fmsci.co.in/>)
- v) Entrant Licence / FMSCI Registration (if any)
- vi) Pan Card copy of Competitor
- vii) 2 Passport size photographs

Competitors are required to carry all the above documents throughout the event. All the documents shall be valid for the date of the event.

Pre-event Scrutineering, Sealing and Marking

8.1 Venue & Timings

Place : **Taneja Aerospace and Aviation Limited, Belagondapalli, Village, Thally Road, Denkanikotta Taluk, Belagondapalli – 635 114, Tamil Nadu - India.**

Date: 27th March 2020

Time: 08:00 to 18:00 Hrs.

Identification of Officials

Safety Marshal	Orange
Safety Officer	Orange with white stripe and text
Post Chief	Blue with white stripe and text
Media	Green
Stage Commander	Red with text
Competitor Relations Officer	Red Jacket or Red Tabard
Medical	White
Radio	Yellow with blue mark
Scrutineer	Black

Prizes

1st Place – Trophy

2nd Place – Trophy

3rd Place – Trophy

Protest & Appeal

NO PROTEST WILL BE ENTERTAINED ON TECHNICAL GROUNDS

12.1 LODGING A PROTEST OR APPEAL

All protests and / or appeals must be lodged in accordance with the stipulations of Articles 13, 14 and 15 of the Code.

12.2 PROTEST FEES

12.2.1 For Closed, Closed Invitation and Open Events, the protest fees is ₹7,080/= (Rupees Seven Thousand Eighty Only) (₹6,000/= +₹1080 GST)

12.2.2 If a protest requires the dismantling and re-assembly of a clearly defined part of the car any additional deposit must be specified in the Supplementary Regulations– or will be specified by the Stewards upon a proposal of the FMSCI Technical Delegate / Chief Scrutineer.

12.2.3 If the protest is overruled or it is withdrawn after being brought, no part of the fee shall be returned. (Article 13.10.1 of FIA International Sporting Code)

12.2.4 If it is proved that the author of the protest has acted in bad faith, the FMSCI may inflict upon them one of the penalties laid down in the Code. (Article 13.10.3 of sporting code)

12.3 APPEALS

₹113,280/= (Rupees One Lakh Thirteen Thousand Two Hundred Eighty Only) (₹96,000/= +₹17,280/= GST)

- Competitors may appeal against decisions, in accordance with the stipulations set out in Articles 15.1 of the Code.
- Competitors have the right to appeal against a sentence or other decisions pronounced on them by the Stewards of the meeting. They must,

however under pain of forfeiture of their right to appeal, notify the Stewards of the Meeting in writing within one hour of the publication of the decision, of their intention to appeal along with a fee of ₹56,640/= (Rupees Fifty Six Thousand Six Hundred Forty only).

- The right to bring an appeal to the FMSCI expires 96 hours after the date of the decision of the Stewards of the event on condition that the intention of appealing has been notified in writing to the Stewards of the event within one hour of the decision (see previous paragraph). This appeal may be brought by fax or by any other electronic means of communication with confirmation of receipt. Confirmation by a letter of the same date accompanied by the necessary fee is required. The FMSCI will give its decision within a maximum of 30 days.
- All parties concerned shall be given adequate notice of the hearing of any appeal. They shall be entitled to call witnesses, but their failure to attend the hearing shall not interrupt the course of the proceedings.
- The confirmation of an appeal to the FMSCI must be accompanied by the grounds of appeal along with fee of ₹113,280/= (Rupees One Lakh Thirteen Thousand Two Hundred Eighty Only).
- This fee becomes due from the moment the appellant notifies the Steward of the intention of appealing, and remains payable even if the appellant does not follow up the declared intention to appeal.
- If the appeal is rejected or it is withdrawn after being brought, no part of the fee shall be returned.
- If judged partially founded, the fee may be returned in part, and in its entirety if the appeal is upheld.
- If it is proved that the author of the appeal has acted in bad faith, the FMSCI may inflict upon them one of the penalties laid down in the Code.

Running of the Event

Distance : 402 metres 1/4 mile

Width of the track : 150 Feet X 7000 Feet

Maximum Number of runs per day including practice : As per G.P

13.1 Format of Racing

STARTING LINE & STAGING PROCEDURES

The class that is to run will be announced, followed by the competition numbers of each bike participating in that class. Competition numbers will be announced in pairs in the order of racing precedence.

The first pair of bikes will be called to the starting line by their competition numbers. When the first bike arrives at the starting line, the second bike has **one (1) minute** to arrive and stage at the starting line.

– Bikes that fail to stage at the starting line within one minute may be immediately disqualified.

There will be no choice of lane.

13.2 Starting lights will be used. The Starting Lights will be 3 Amber light followed by a Green light for GO,

13.3 The bikes will be judged according to timings. Timing will be recorded by a laser trigger. The timing will be recorded from the time the lights go GREEN up to when the rider crosses the finish line.

13.4 If a rider makes a false / jump-start, the RED light will come on and the participant will be EXCLUDED from that particular run. If the lights fail, there shall be a manual timing system for that entire class. For the classes that have already been completed, the timing light time shall remain. There shall be no Protest entertained on Jump Starts and Timings when the Timing Equipment is used.

13.5 Only Riders along with their competing vehicles shall be allowed in the starting area and for Line-Up. No other person shall be allowed into the starting area.

13.6 Once the vehicle has finished its run, the competitors have to go to the end of the Track and return via the road for which the speed limit will be 30Kms/hr. The competitors may have to wait to be escorted back by the organizers.

13.7 The procedures and other details of the drag shall be informed to all competitors at the Briefing Meeting.

13.8 The CLASS & CATEGORY Winners will be determined by the fastest timings. All class/category-winning vehicles will be then taken to Parc Ferme for post event scrutiny.

13.9 The bikes used for qualifying cannot be changed on the race day. If done will entail disqualification.

Safety Requirements

AS per G.P

Names and photographs of CRO's

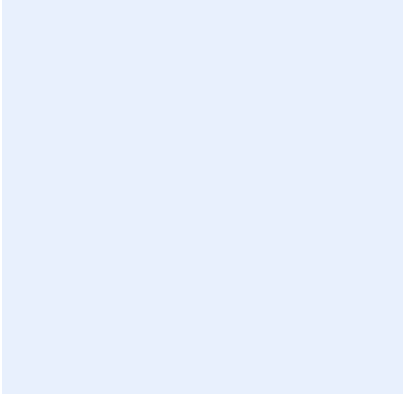
	
TARIQ MOHSIN	CRO NAME
7022450500	MOBILE
tariq.m@genevaservices.in	email

Will be present at:

- At the Secretariat.
- At the start of the scrutineering.
- Near the "PIT AREA".

NOTES / WAIVERS

The rider or his official representative must present any bike taking part in the event to Scrutinizing. Competitors reporting later than their schedule will be penalized by Rs.100/- per minute later than their slot up to maximum of 30 minutes lateness allowed, after which they may be disqualified.

1 Each bike must carry the competition number and the advertising stickers provided by the Organizers. The details of where to put the advertising stickers and the competition number will be given at the briefing meeting. The competitors are allowed to carry any other kind of advertisements on their bike provided that: (a) it is authorized by the National laws and FMSCI regulations (b) it is not likely to cause any offence (c) it is not political or religious in nature (d) it does not encroach upon the space reserved for plates, competition number and organizers stickers (e) it does not interfere with rider vision.

2 Top three 2-Wheelers in each category will be subject to compulsory post event scrutiny. Other finishers will be held in parc ferme and can only leave on the approval of the organiser. The participants must come prepared with their own mechanics at the time of Scrutiny.

3 The Scrutineers of the event at their discretion can dismantle any competitor's 2-wheeler for inception at any given time during the course of the event.

4 PIT CREW - Each rider shall be given 1 pit pass per bike entered. Photographs for the pit crew should be presented at the time of documentation.

5. ADVERTISING

The competitors are allowed to carry any other kind of advertisements on their bike provided that

It is authorized by the National laws and FMSCI regulations

It is not likely to cause any offence

It is not political or religious in nature

It does not encroach upon the space reserved for plates, competition number and organizers stickers

It does not interfere with rider's vision.

The competition numbers and compulsory stickers shall be affixed on the vehicles before scrutineering and shall remain affixed throughout the event.

6. APPAREL - Each member of a participant crew must be fully attired when present in the staging, starting and competition areas of the race track. Shoes are mandatory. Shorts, bare legs, tank tops, or bare torsos are prohibited when driving in any class. See Class Requirements

7. APPEARANCE - Vehicles participating in drag racing events must be presentable in appearance at all times; those considered improperly prepared may be rejected by the scrutineer. The appearance of personnel attending contestant vehicles is equally important, and is subject to the same considerations.

8 PENALTIES

8.1 False Start / Jump Start: A false start occurs when the vehicle moves forward or backwards from the prescribed position before the Green lights. The penalty for this is DISQUALIFICATION .However a competitor can only take one jump start re run per class as per the following table.

Category	Amount
Indian 2 Wheelers	1500
Foreign 2 Wheelers	2000
Indian 4 Wheelers	4000
Foreign 4 Wheelers	5000

The Start Marshal's decision will be Final.

8.2 Refusal to obey officials of the meet- left to the discretion of the Steward.

8.3 Riding dangerously in restricted area - left to the discretion of the Steward.

8.4 Crossing of centre line – DISQUALIFICATION

8.5 If a competitor arrives late for starting, he/she shall not be allowed to start.

8.6 Any rider found riding fast, rashly or negligently, or practicing or tuning their bikes on the track may be DISQUALIFIED

8.7 Any competitor who does not have his / her I.D. Tag shall not be allowed to start.

8.8 There will be a speed limit on the return run of 30 KMPH. Any competitor found breaking this speed limit MAY BE DISQUALIFIED

8.9 The Stewards of the meet may adjudicate on any matter not covered by these regulations and impose penalties in accordance with the Code.

8.10 Burnout are allowed for vehicles running 'DRAG SLICK TYRES' only in the prescribed area on the drag strip any infringement by the competitor will attract a cash penalty of Rs.1500 per run.

8.11 A racer found not conforming to these Supplementary regulations or by refusing to make their vehicle available for inspection may be disqualified from the event.

8.12 Disqualification if a bike found over bored beyond its cubic capacity allowed in its class.

8.13 The bikes used for qualifying cannot be changed on the race day. If done will entail disqualification.

8.14 Winner's vehicles from each class will be subject to a complete post event scrutiny for which the owner will bear costs.

8.15 Not present at driver's briefing report to Stewards and cash penalty up to Rs 2500.

Article 9 RESULTS

9.1 Results will be posted on the official notice board after each race.

9.2 Results will also be displayed on screens after each race

9.3 Reaction Time (RT) + Elapsed Time (ET) = Final Time (FT)

9.4 **Tie Breaker:** In case of a tie, the competitor with the least reaction time shall be declared the winner. Reaction time is the time taken by a competitor to take off after the Green GO Light comes on. If the Tie is still not resolved, the award/s will be divided amongst both the competitors.

9.5 If a vehicle is disqualified for technical or whatever reason, the vehicle placed behind him will move up to take the position.

APPENDIX 1: COMPETITION NUMBERS & ADVERTISING

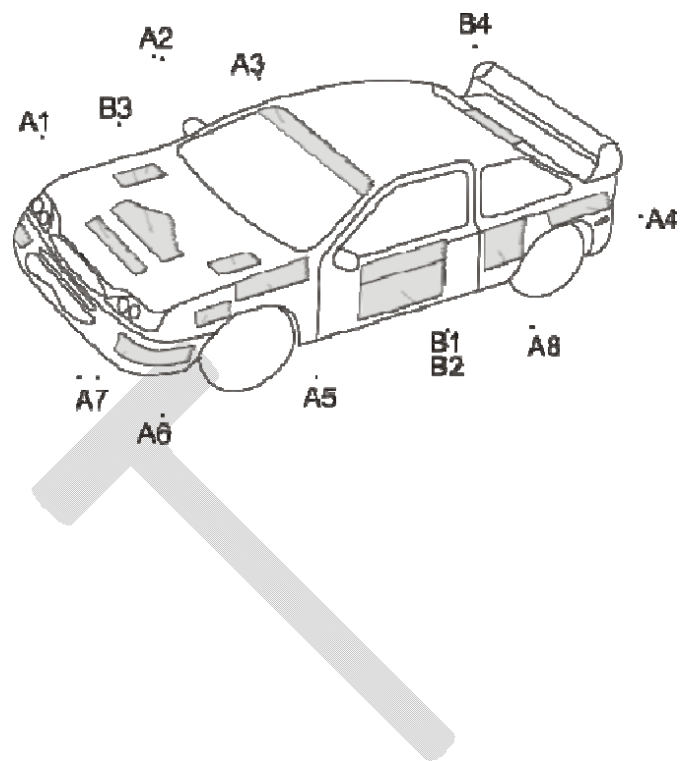

- A1 : TBA
- A2 : Club/Sponsor
- A3 : Sponsor
- A4 : Sponsor
- A5 : TBA
- A6 : TBA
- A7 : TBA
- B1 ~ B3: Competition Number